

## **WEIGHING SCALES DESIGN FOR BALANCING LONGITUDINALLY AN UNMANNED AERIAL VEHICLE**

**Konstantin Metodiev**

*Space Research and Technology Institute – Bulgarian Academy of Sciences*  
e-mail: komet@space.bas.bg

**Keywords:** *Wheatstone bridge, microcontroller unit, unmanned aerial vehicle*

**Abstract:** *In the paper hereby, an exemplary design of weighing scales is proposed. The device has been designed for figuring out mass center longitudinal coordinate of a remotely controlled aircraft. The device essentially comprises a load cell including a Wheatstone bridge with strain gauges and a 24-bit analog to digital converter interfacing a data logging microcontroller unit. The load cell design was investigated by means of Autodesk Inventor and Finite Element Analysis was carried out further in order to find an area with maximum equivalent strain. This area is considered best suited to mounting the strain gauge. The calibration stage was subsequently performed in order to get the device response in terms of etalon weight values.*

*The project goal is to examine the weight scales response thoroughly so as to make use of them on the unmanned airplane available in the department of Aerospace Control Systems.*

## **ПРОЕКТ НА ВЕЗНИ ЗА НАДЛЪЖНА БАЛАНСИРОВКА НА БЕЗПИЛОТЕН САМОЛЕТ**

**Константин Методиев**

*Институт за космически изследвания и технологии – Българска академия на науките*  
e-mail: komet@space.bas.bg

**Ключови думи:** *Мост на Уитстон, микроконтролер, безпилотен самолет*

**Резюме:** *В настоящата статия е предложен примерен проект на авиационни везни. Везните са проектирани за определяне на надлъжната координата на масовия център на безпилотен самолет. Устройството представлява динамометър, включващ мост на Уитстон с тензометричен възприемател и 24-битов аналого-цифров преобразувател, който е свързан с микроконтролер за събиране на данни. Динамометърът беше изследван в среда Autodesk Inventor и анализиран по Метода на крайните елементи, за да се намери област с най-голяма деформация. Тази област се счита най-подходяща за монтаж на чувствителния елемент. В следствие беше извършена калибровка, за да се намерят показанията на устройството за различни еталонни тегла.*

*Целта на проекта е да се изследва подробно устройството на динамометъра, за да се използва на безпилотен самолет, наличен в секция „Аерокосмически системи за управление“.*

### **Introduction**

The paper hereby outlines yet another approach towards working out a solution to the problem of aircraft longitudinal balance. The mass center longitudinal coordinate is among the most important flying and maneuvering characteristics of an aircraft. The aircraft is said to be longitudinally stable in terms of the load factor value if the mass center is located ahead of the aerodynamic center. This condition ensures that the airplane might be trimmed during flight and able to fly along a straight path with hands off controls. The mass center location varies within certain limits. If it is too far aft, the airplane will be sensitive to applied controls and difficult to be brought back to longitudinal equilibrium. On the other hand, if the mass center is too far forward, the airplane will be excessively stable and difficult to pitch up/down which might be dangerous during take-off and landing.

The presented study aims at coming up with an easy-to-build tool in an effort to estimate the longitudinal coordinate of the aircraft mass center.

## Materials and methods

The experimental setup is depicted in Fig. 1. It consists of three weighing scales placed right beneath the airplane tires. The scales are connected to a manifold box containing a signal conditioning unit, an analog to digital converter, and a microcontroller unit solely interfacing a PC. Not only does the PC store data but it also works out a solution to the statistical problem and (optionally) displays a graphical interface for the technician to figure out longitudinal coordinate of the mass center in real time and adjust the payload weight and placement if necessary.

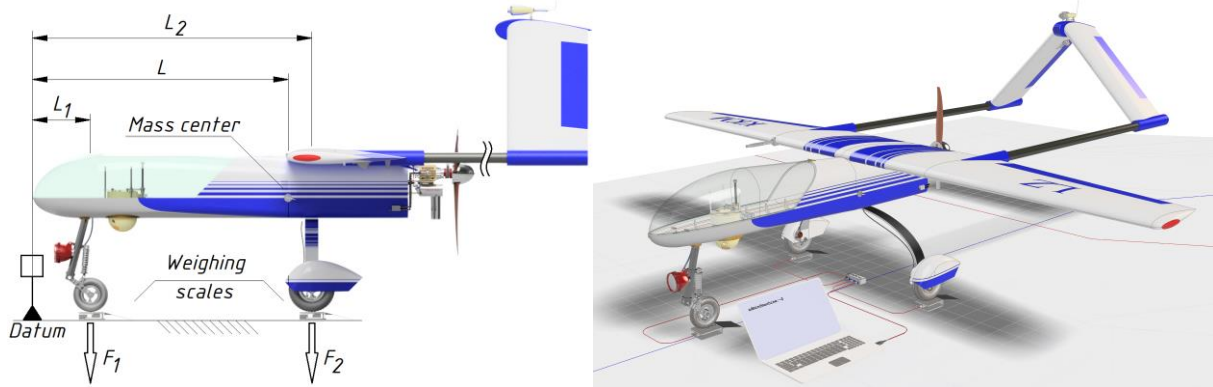

Fig. 1. Forces and distances layout (left) and the experiment outline

Having taken scales measurements, it becomes possible to obtain the mass center longitudinal coordinate by working out a solution to the equation:

$$(1) \quad L = \frac{\sum_i L_i F_i}{\sum_i F_i},$$

which essentially gives how many times the total weight goes into the first moment of inertia. There is no obligatory site at which the datum is to be put up. Instead, a suitable place must be selected that will not change during lifespan of the aircraft, [1], for instance the canopy tip, Fig. 1. Then, for each measured weight, following exemplary table might be written down, [2], in accordance with formula (1) and Fig. 1. It is assumed that the aircraft has been initially balanced in lateral direction.

Table 1. Exemplary computations according to Fig. 1

Weight, kg	Arm, m	Torque, kg.m	Mass Center, m
F1 = 5.5	L1 = 0.5	L1*F1 = 2.75	
F2 = 25	L2 = 1.5	L2*F2 = 37.5	
F2 = 25	L2 = 1.5	L2*F2 = 37.5	
ΣF = 55.5		Σ(L*F) = 77.75	L = 1.4

In Table 1, two main wheels have been taken into account, which is the reason why the torque  $L_2 * F_2$  is computed twice. The weighing scales placement is depicted in detail in Fig. 2.

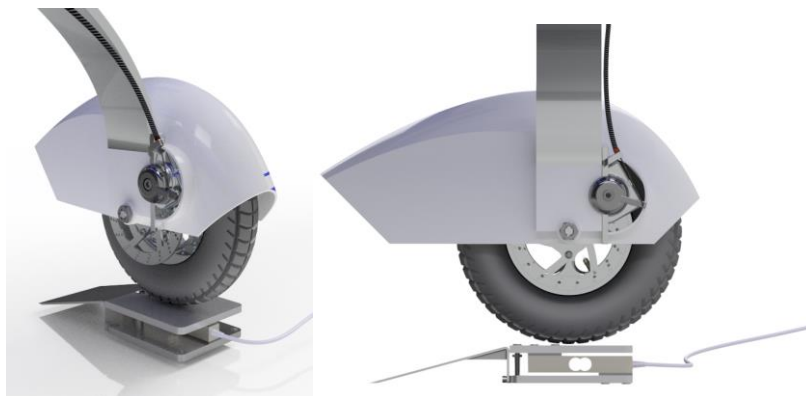

Fig. 2. Load cell mechanical design placed beneath the airplane main wheel

The project circuit is depicted in Fig. 3. It comprises following units: an active half-bridge, a 24-bit  $\Sigma\Delta$  analog to digital converter (ADC) HX711 [3], ATmega644P microcontroller unit (MCU) [4], and MAX232 serial data converter (TTL – RS232) interfacing a PC. The bridge circuit includes two fixed resistors and two gauges of 1 k $\Omega$  each. The bridge output is converted by the HX711 ADC. A proprietary serial communication protocol is used to establish communication between the ADC and the MCU. The source code is published in the Appendix section.

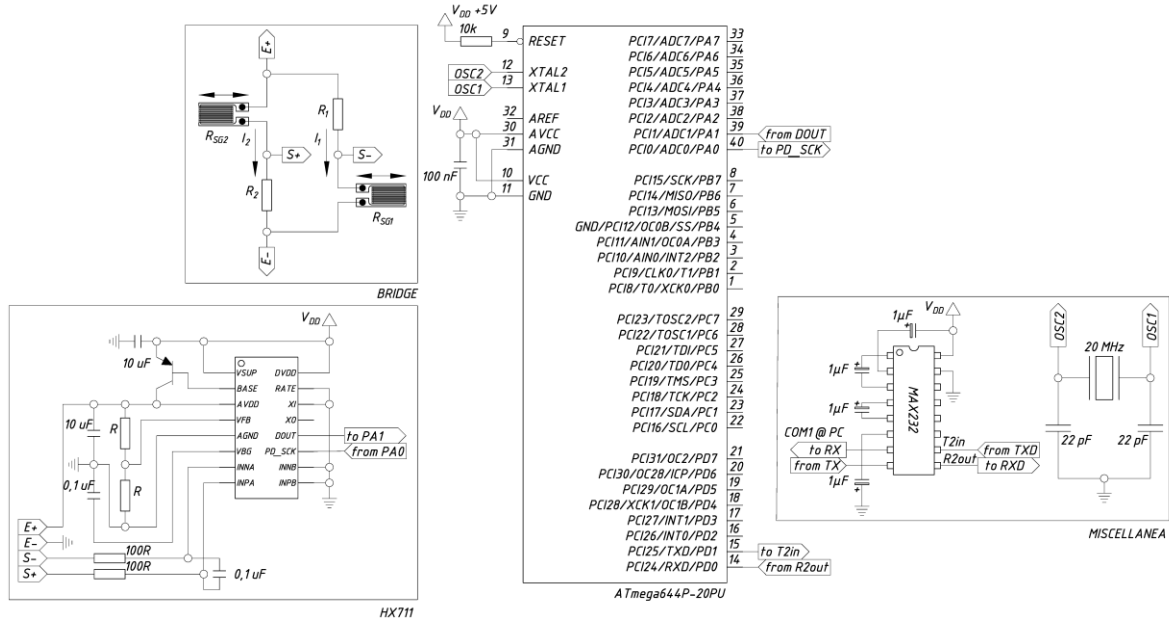

Fig. 3. Project schematics

The Wheatstone bridge analysis aims at working out value of the voltage difference  $V^+ - V^-$  according to Fig. 3. For currents which flows through each leg (see the bridge section) it might be written that

$$(2) \quad I_1 = \frac{AV_{DD}}{R_1 + R_{SG1}} \quad I_2 = \frac{AV_{DD}}{R_{SG2} + R_2}$$

and voltage drops across resistors  $R_2$  and  $R_{SG1}$  are

$$(3) \quad V_2 = I_2 R_2 \quad V_{SG1} = I_1 R_{SG1}$$

Hence, after substituting for currents  $I_1$  and  $I_2$ , it yields

$$(4) \quad V^+ - V^- = AV_{DD} \left( \frac{R_2}{R_2 + R_{SG2}} - \frac{R_{SG1}}{R_1 + R_{SG1}} \right)$$

In order to balance the bridge, the following requirement must be met  $V^+ - V^- = 0$  which implies

$$(5) \quad \frac{R_1}{R_{SG1}} = \frac{R_{SG2}}{R_2}$$

The proposed bridge configuration is called “half bridge.” It is twice as sensitive as the quarter bridge. Both gauges are mounted on opposite sides of the load cell so as to experience equal loads with different signs. In this way, tensile stress is applied to one gauge whilst compression stress is applied to the other. The adopted idea is depicted in following Fig. 4.

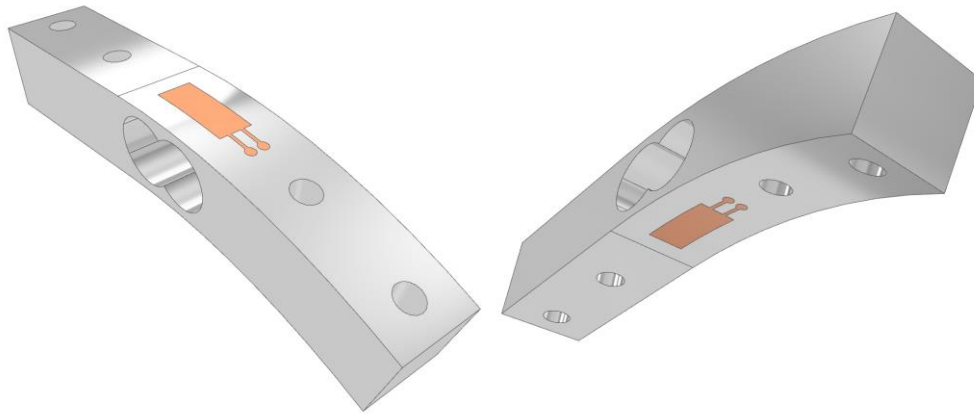

Fig. 4. Strain gauges placement onto the cell in half-bridge configuration

A Chinese load cell YZC-133 with load span of 10 kg was used in the current study. The cell outline is depicted in Fig. 5. The overall dimensions are 13 mm/13 mm/80 mm. In order to find out a spot best suited for mounting the sensing element, a finite element analysis (FEA) was carried out by means of a FEA tool readily available in Autodesk Inventor. The strain/stress relationship was obtained in order to figure out an area with maximum strain. The area is considered the most suitable place where the gauge is to be placed. In Fig. 5, the computational mesh is visible, so are the applied force and the fixed constraints.

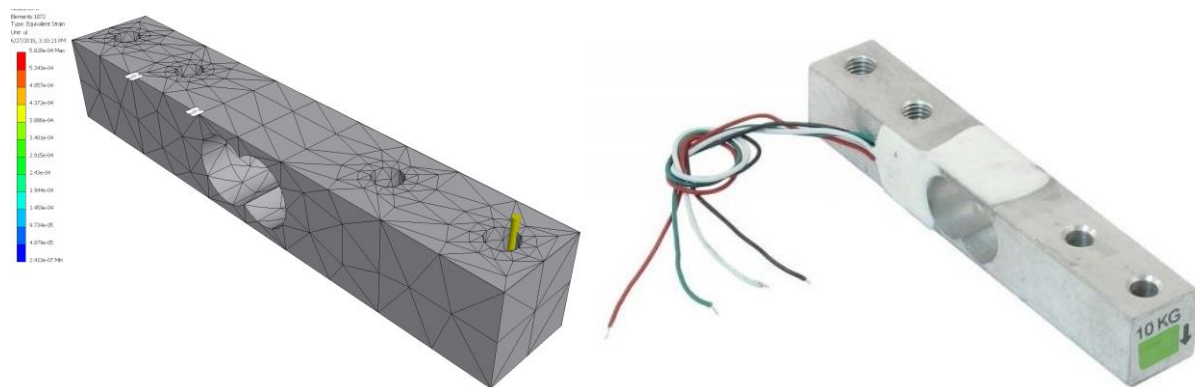

Fig. 5. Computational mesh over a load cell YZC-133 (left) and the prototype itself

The calibration procedure was performed as follows. For purpose of comparison, a weighing scale with accuracy of  $\pm 2.5$  gram was used as a reference gauge. A number of fixed weight values were delivered in succession and the output ADC values were logged afterwards. Then, a regression line was fitted to the observed data previously assumed to have been normally distributed. For this reason, no less than 30 measurements must have been taken for each etalon weight. Histogram were drawn afterwards as well as computing values of standard error and confidence interval.

## Results

In Fig. 6, the results obtained after carrying out FEA analysis show equivalent strain distribution over the load cell. The applied force value is 100 N and the assigned material is Aluminum 2014-T6 (AlCu4SiMg). The strain maximum values (dimensionless) are depicted in red indicating in this way a place best suited for mounting the sensing element.

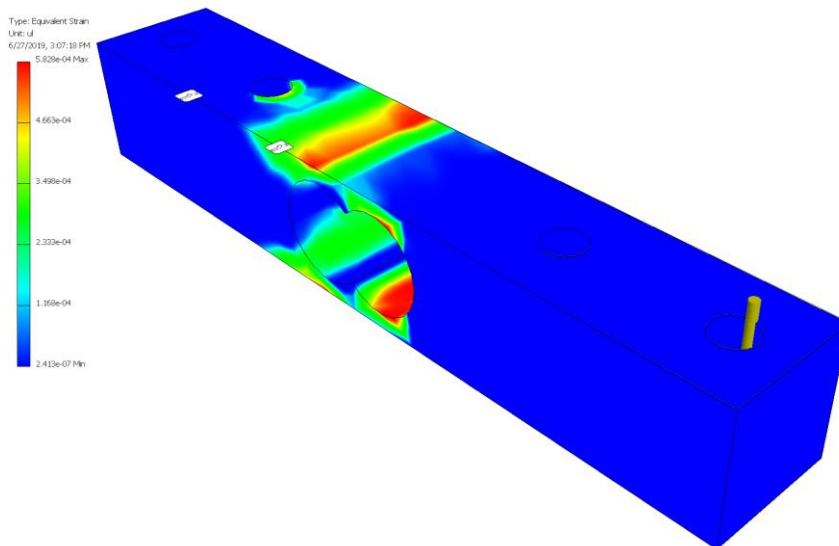

Fig. 6. Equivalent strain distribution over the cell subject to a load of 100 N

Table 2 shows mean values of etalon weights applied to the cell during calibration stage.

Table 2. Calibration data

Mean, ADC levels	stddev	stderr	conf, 0.95
56624	61	11	0.689797
290951	248	45	2.793699
524819	589	106	6.638381
751867	882	158	9.93213
962195	4388	788	49.42468
1419683	1167	210	13.14609

In Fig. 7, the best fit line is shown, so are the equation of line and the correlation coefficient. In Fig. 8 the histograms are shown for mean values of samples with size of 31 measurements each.

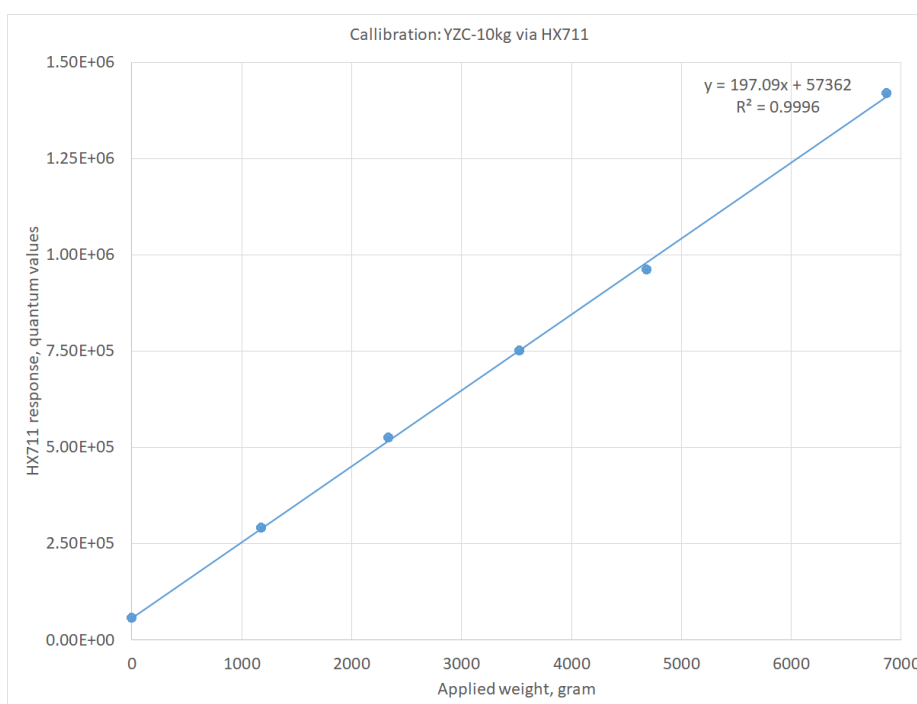

Fig. 7. Calibration curve for YZC-133 10 kg, HX711 24-bit ADC

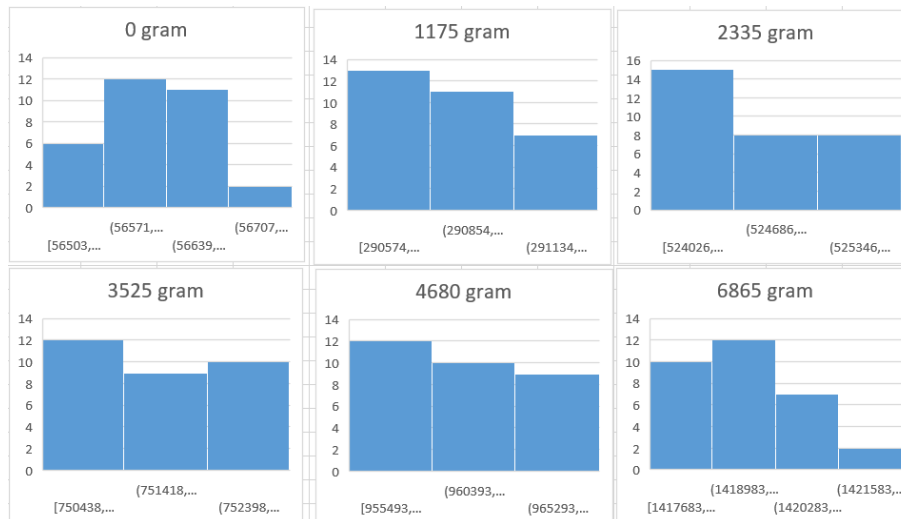

Fig. 8. Histograms for all experimental runs with 31 sample points each

## Discussion

The correlation coefficient value  $R^2 \approx 1$  indicates a strong relationship between measured and estimated data. The histograms in Fig 8 show that samples happen not to converge toward the mean value which is a significant drawback indicating a low sensor repeatability.

Perhaps, the most important topic is making use of a signal conditioning module, or rather, its absence in the adopted schematics in Fig 1. The HX711 ADC contains a programmable gain amplifier with values of 32, 64, and 128. The module main purpose is to amplify the signal for the ADC to be able to convert it. This module is frequently referred to as instrumentational amplifier. Apart from the high-resolution ADC mentioned in the paper, INA333, [5], amplifier was also used in the current study alternatively for validation purposes. The amplifier input offset voltage is well below the bridge sensitivity, i.e. 25  $\mu\text{V}$ . Having been amplified, the signal enters a 12-bit ADC ADS1015 [6]. To sum up, both approaches towards carrying out this particular experiment are equally admissible. Whether either of them is applicable or not is a matter for the scholar to decide.

In the presented study, trial versions of Autodesk Inventor v.2020 and MikroC Pro for AVR v.7.0.1 were used. Both UAV and weighing scales models might be downloaded for free at [7] and [8].

## References:

1. Aviation Maintenance Technician Handbook, FAA-H-8083-30, Ch. 4, Aircraft Weight and Balance, U.S. Department of Transportation, Federal Aviation Administration
2. Weight and Balance Handbook, FAA-H-8083-1B, U.S. Department of Transportation, Federal Aviation Administration.
3. HX711, 24-Bit Analog-to-Digital Converter (ADC) for Weigh Scales, Avia Semiconductor data sheet.
4. ATmega644P/V, Datasheet Complete, Atmel.
5. INA333 Micro-Power (50 $\mu\text{A}$ ), Zero-Drift, Rail-to-Rail Out Instrumentation Amplifier, Datasheet, Texas Instruments.
6. ADS101x Ultra-Small, Low-Power, I2C-Compatible, 3.3-kSPS, 12-Bit ADCs with Internal Reference, Oscillator, and Programmable Comparator, Datasheet, Texas Instruments.
7. <https://grabcad.com/library/flight-of-fancy-1>
8. <https://grabcad.com/library/load-cell-25>

## Appendix

```
// Code for getting data from HX711 24-bit ADC, ATmega644P MCU
// Mikro C Pro for AVR, v.7.0.1, Mikroelektronika LLC

#define nl() UART1_Write(13); UART1_Write(10)

signed long readHX711() {
signed long x = 0;
int i, gain = 1; // gain = 1...3

    for (i = 0; i < 24; i++) {
        PORTA.F0 = 1;
        x <<= 1;
//        Delay_us(50); // optional
        PORTA.F0 = 0;
        x |= PINA.F1;
    } //for_i

    for (i = 0; i < gain; i++) {
        PORTA.F0 = 1;
        asm { nop }
        PORTA.F0 = 0;
        asm { nop }
    } //for_i

    return x;
} //readHX711

void main() {
signed long res;
char txt[12];

    DDRA = 0b00000001; // PA0-clock; PA1-data; 1-output; 0-input
    PORTA = 0x00;
    UART1_Init(57600);

    while (1) {
        res = readHX711();
        LongToStr(res, txt);
        UART1_Write_Text(txt); nl();
        delay_ms(250);
    } //while_1

} //main
```